

Isolated Word Recognition

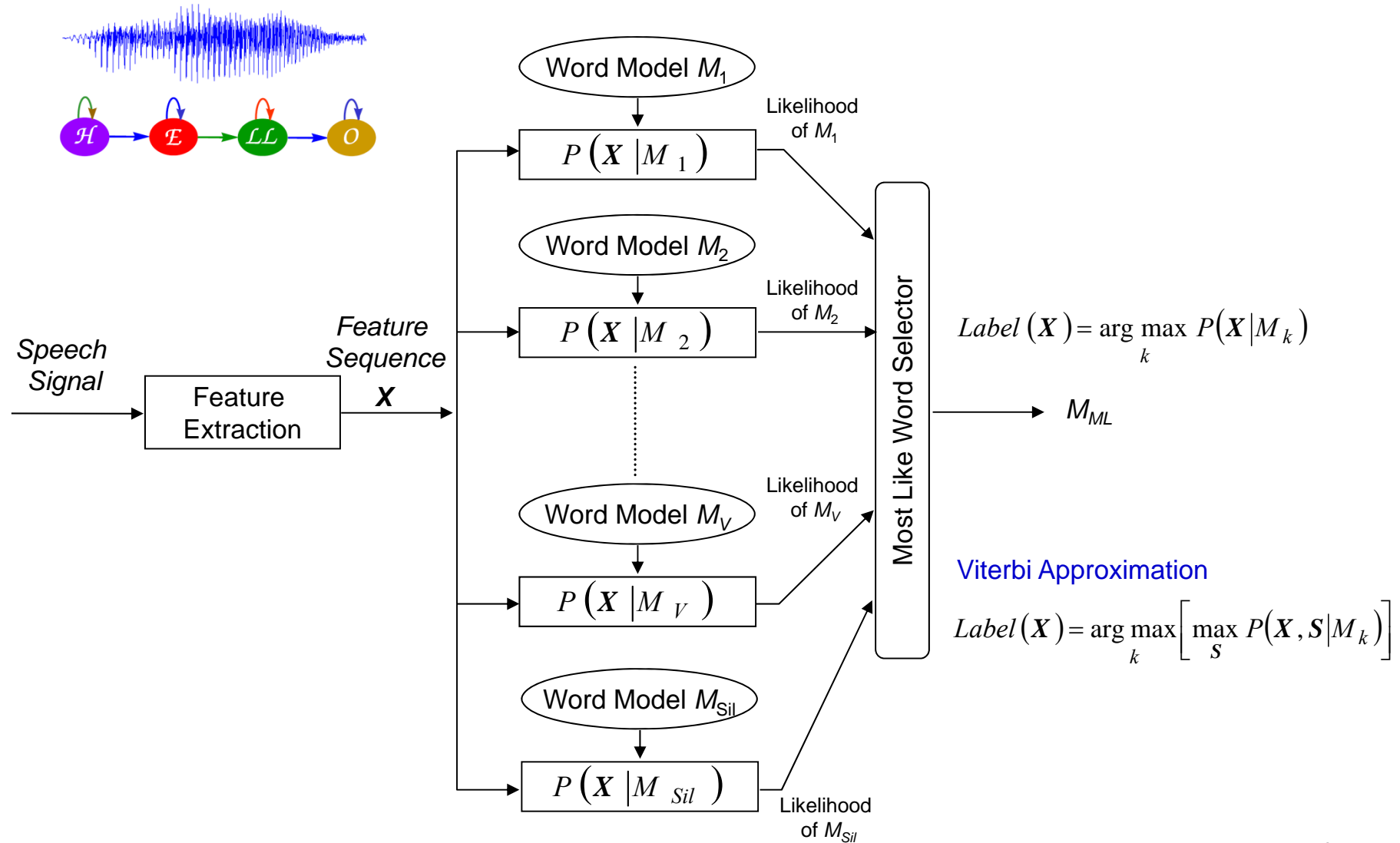

```

////////////////////////////////////
int Len[MAX_NAME]; //存放每個人名的HMM的model數
int HMM_ID_List[MAX_NAME][MAX_LEN]; //存放每個人名所用到的HMM的model的編號ID
float Delta[MAX_NAME][MAX_LEN][MAX_STATE]; //Viterbi 中的 delta(t)
float Score[MAX_NAME]; //每個人的分數
char Name[MAX_NAME][20]; //儲存人名的中文字

```

```

int Name_No; //實際人名的個數
////////////////////////////////////

```

.....

```

getcwd(Directory,200); //取得本程式執行位置
//////初始工作 ////
Allocate_Model_Memory((int)151); //Allocate HMM Model Memory,初設最多有 160 HMM
Set_Const();//for feature extraction
//////讀入 HMM models////
sprintf(ModelPath,"%s\\HMM_model",Directory);
printf("%s \n",ModelPath);
Load_HMM_FILES(ModelPath);
printf("Model[total=%3d] Loading OK...\n",Total_HMM);
//////讀入 每個人名及其對應之 HMMs ////
Read_Name_Information();
//////讀入 wave 檔 辨識////
if ((WAVSRC = fopen(buf,"rb"))==NULL)
{
printf("Open WaveFile: %s Error!!\n",buf);
getchar();
exit(1);
}
filesize=filelength(fileno(WAVSRC));
speechdata=(short *)data;
fread(data,filesize,1,WAVSRC);
fclose(WAVSRC);
Front_End=0;
Back_End=filesize/2; //因為每一個 sample為2 bytes

```

```

struct Model_struct
{
char Name[20];
short State;
short Phone_ID;
float Mean[Num_State][Max_Mix][Vec_Size];
float Var[Num_State][Max_Mix][Vec_Size];
float Trans[Num_State][Num_State];
float GConst[Num_State][Max_Mix];
float Mix_Weight[Num_State][Max_Mix];
short Mix[Num_State];

};
struct Model_struct *Model;
//存HMM models的 structure

```

```

Total_Frame=Feature(); //Calculate feature vector
//feature vector存在 Cep_Data1[j][i]
//j是time index, i 是 vector dimension index
printf("Total Frame Num (Total feature vector Num)=%d\n",Total_Frame);

////////////////////////////////////
for (i=0;i<Total_Frame;i+=1) //Calculate model state observation in advance
    for (j=0;j<Total_HMM;j++)
        for (k=1;k<Model[j].State-1;k++)
            Get_Fil_B(i,j,k);
printf("State Observation Calculation OK\n");
//結果以log(prob) (取log) 形式存在存在 B_O[Max_Frame_Num][160][Num_State];
////////////////////////////////////Initializatiog for Viterbi Search //////////////////////////////////////

```

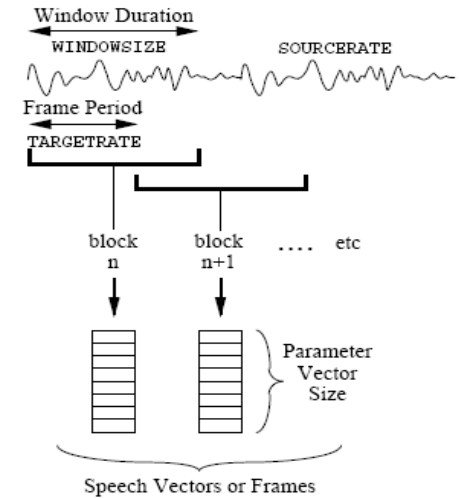

```

for(name_id=0;name_id<Name_No;name_id++)//Names
    for(int model_len=0;model_len<Len[name_id];model_len++)//HMM models for a specific name
        for(int k=0;k<Model[HMM_ID_List[name_id][model_len]].State;k++) //HMM state
            Delta[name_id][model_len][k]=(float)Min_Delta;

for(name_id=0;name_id<Name_No;name_id++)
    Delta[name_id][0][0]=(float)0.0;

```

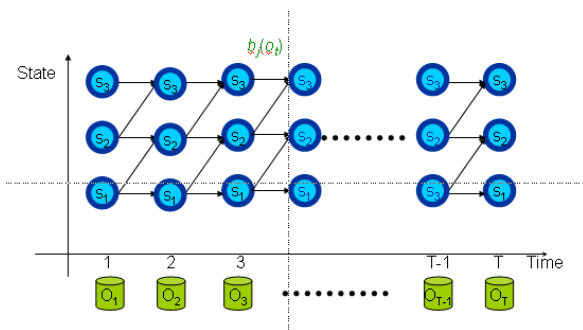

```

for(frame=0;frame<Total_Frame;frame++) //輸入語句有多少個feature vectors
{
  for(name_id=0;name_id<Name_No;name_id++) //對於所有人名展開HMM平面
  {
    for(model_len=Len[name_id]-1;model_len>=0;model_len--) //HMM models for a specific name
    {
      for(k=Model[HMM_ID_List[name_id][model_len]].State-2;k>=1;k--)//HMM state
      {
        val1=Delta[name_id][model_len][k-1]+Model[HMM_ID_List[name_id][model_len]].Trans[k-1][k];//來自前一個時間、前一個狀態
        val2=Delta[name_id][model_len][k]+Model[HMM_ID_List[name_id][model_len]].Trans[k][k];//來自前一個時間、同一個狀態
        if(val1 > val2)
          max_val=val1;
        else
          max_val=val2;
        Delta[name_id][model_len][k]=max_val+B_O[frame][HMM_ID_List[name_id][model_len]][k];
      } //for HMM state

      Delta[name_id][model_len][0]=Delta[name_id][model_len-1][Model[HMM_ID_List[name_id][model_len-1]].State-2]
        +Model[HMM_ID_List[name_id][model_len-1]].Trans[Model[HMM_ID_List[name_id][model_len-1]].State-2]
          [Model[HMM_ID_List[name_id][model_len-1]].State-1];

    } //for Model_len
    Delta[name_id][0][0]=(float) Min_Delta;
    Score[name_id]=Delta[name_id][Len[name_id]-1][Model[HMM_ID_List[name_id][Len[name_id]-1]].State-2];
  } //for name_id
} //for speech frame

float max_val=(float) Min_Delta;
Top1_Index=-1;
for (name_id=0;name_id<Name_No;name_id++)
{
  if(Score[name_id]>max_val)
  {
    max_val=Score[name_id];
    Top1_Index=name_id;
  }
}

```

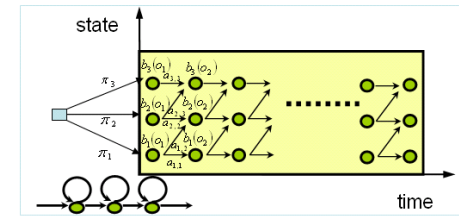

```

void Get_Fil_B(int i, int j, int k)
{
    double diff[Max_Mix];
    double MAX;
    int m, n;
    double value,value2;
    double temp;

    MAX = 1.0e30;
    double sum=(double)0.0;

    for (m=0;m<Model[j].Mix[k];m++)
    {
        diff[m] =(double) 0.0;
        for (n=0;n<Vec_Size;n++)
        {
            value=(double)Cep_Data1[i][n]-(double)Model[j].Mean[k][m][n];
            diff[m] += value*value*(double)Model[j].Var[k][m][n];
        }
        if(!_finite(diff[m])==0||_isnan(diff[m])!=0||diff[m]<(double)1.0E-30)
            diff[m]=(double)1.0E-30; //check if underflow
        temp=(double)(diff[m]+(double)Model[j].GConst[k][m])*(double)(-0.5);
        value2=exp(temp);
        sum+=value2*(double)Model[j].Mix_Weight[k][m];
    }

    B_O[i][j][k] = (float)log(sum); //stored in log domain
}

```

$$f(\mathbf{X} = \mathbf{x} | \boldsymbol{\mu}, \boldsymbol{\Sigma}) = N(\mathbf{x}; \boldsymbol{\mu}, \boldsymbol{\Sigma}) = \frac{1}{(2\pi)^{L/2} |\boldsymbol{\Sigma}|^{1/2}} \exp\left(-\frac{1}{2}(\mathbf{x} - \boldsymbol{\mu})' \boldsymbol{\Sigma}^{-1}(\mathbf{x} - \boldsymbol{\mu})\right)$$

if a diagonal covariance matrix is assumed

$$N(\mathbf{x}; \boldsymbol{\mu}, \boldsymbol{\Sigma}) \approx \frac{1}{(2\pi)^{L/2} \begin{vmatrix} \sigma_{1,1} & & \\ & \sigma_{2,2} & \\ & & \ddots \\ & & & \sigma_{L,L} \end{vmatrix}^{1/2}} \exp\left(-\frac{1}{2} \sum_{l=1}^L \frac{1}{\sigma_{l,l}} (x_l - \mu_l)^2\right)$$

$$\approx \frac{1}{(2\pi)^{L/2} (\sigma_{1,1} \times \sigma_{2,2} \times \dots \times \sigma_{L,L})^{1/2}} \exp\left(-\frac{1}{2} \sum_{l=1}^L \frac{1}{\sigma_{l,l}} (x_l - \mu_l)^2\right)$$

∴

$$\log N(\mathbf{x}; \boldsymbol{\mu}, \boldsymbol{\Sigma}) \approx -(0.5) \times Gconst - \frac{1}{2} \sum_{l=1}^L \frac{1}{\sigma_{l,l}} (x_l - \mu_l)^2$$

where

$$Gconst = L \times \log(2\pi) + \sum_{l=1}^L \log \sigma_{l,l}$$

